A fast method for sequence component filtering

Y. G. Paithankar and S. R. Bhide

*Department of Electrical Engineering, Visvesvaraya Regional College of Engineering,
Nagpur, India*

E-mail: ygp@vrce.ernet.in

Abstract In this paper a method to filter or segregate sequence components, using minimal hardware is presented. The method does not involve phase shifts other than that of 90 degrees. Thus it can be implemented using very simple hardware or if implemented in software will need considerably less amount of processing. The method consists in first separating the zero sequence component. Then the zero sequence component is subtracted from the input signal to get a signal which is sum of positive and negative sequence components. Further it is pointed out that difference between positive and negative sequence components is easily found from the difference of the phase quantities. Thus the sum and difference of positive and negative sequence components are available, from which individual positive and negative sequence components can be easily separated by simple addition and subtraction operations.

The theory of symmetrical component decomposition was invented by C. L. Fortesque in 1950¹ and is briefly reproduced here. The unbalanced phasors can be broken down into three sets of balanced phasors as shown in Fig. 1.

The same is expressed mathematically as shown below.

$$I_a = I_{a1} + I_{a2} + I_{a0} \quad (1)$$

$$I_b = I_{b1} + I_{b2} + I_{b0} \quad (2)$$

$$I_c = I_{c1} + I_{c2} + I_{c0} \quad (3)$$

$$I_{a0} = I_{a0} = I_{a0} \quad (4)$$

$$I_a = I_{a1} + I_{a2} + I_{a0} \quad (1)$$

$$I_b = a^2 I_{a1} + a I_{a2} + I_{a0} \quad (5)$$

$$I_c = a I_{a1} + a^2 I_{a2} + I_{a0} \quad (6)$$

$$\begin{bmatrix} I_{a0} \\ I_{a1} \\ I_{a2} \end{bmatrix} = (1/3) \begin{bmatrix} 1 & 1 & 1 \\ 1 & a^2 & a \\ 1 & a & a^2 \end{bmatrix} \begin{bmatrix} I_a \\ I_b \\ I_c \end{bmatrix} \quad (7)$$

From the above we get: –

$$I_{a0} = (1/3)(I_a + I_b + I_c) \quad (8)$$

A review of conventional methods of sequence component filtering shows that these methods achieve the filtering by directly carrying the complex transformation between the unbalance phasors and the desired sequence components. This leads to

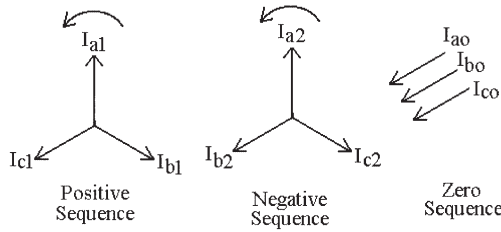

Fig. 1 The Sequence Components.

circuits of considerable complexity.² As shown in the next section, it is possible to achieve the same using a much simpler approach.

The proposed method

Zero sequence components

From equation (8), zero sequence component is the one which can be filtered out most simply by simple summation operation.

Sum of positive and negative sequence components

Thus from equation (1) we can find the sum of positive and negative sequence components as: –

$$I_a = I_{a1} + I_{a2} + I_{a0} \tag{1}$$

$$I_{a1} + I_{a2} = I_a - I_{a0} \tag{9}$$

Difference of positive and negative sequence components

$(I_{a1} - I_{a2})$ can be easily established from equations (5) and (6) as follows: –

$$I_b = a^2 I_{a1} + a I_{a2} + I_{a0} \tag{5}$$

$$I_c = a I_{a1} + a^2 I_{a2} + I_{a0} \tag{6}$$

$$\begin{aligned} I_b - I_c &= (a^2 - a)I_{a1} + (a - a^2)I_{a2} \\ &= (a^2 - a)I_{a1} - (a^2 - a)I_{a2} \\ &= (a^2 - a)(I_{a1} - I_{a2}) \end{aligned}$$

$$(I_{a1} - I_{a2}) = (I_b - I_c) / (a^2 - a) \tag{10}$$

However $(a^2 - a) = \sqrt{3} \angle -90^\circ$, therefore

$$(I_{a1} - I_{a2}) = (I_b - I_c) / \sqrt{3} \angle -90^\circ \tag{11}$$

$$(I_{a1} - I_{a2}) = ((I_b - I_c) \angle 90^\circ) / \sqrt{3} \tag{12}$$

Thus finding the difference between the positive and negative sequence components involves correcting the difference between two line currents by $(1/\sqrt{3})$ in magnitude

and shifting it in 90° by phase. The phase shift of 90° can easily be created by a transactor (i.e., an air gapped transformer) and correction in magnitude is a simple matter of correcting auxiliary CT ratio.

The separation of positive and negative sequence components

The sum and difference terms are reproduced below:

$$I_{a1} + I_{a2} = I_a - I_{a0} \quad (9)$$

$$I_{a1} - I_{a2} = ((I_b - I_c) \angle 90^\circ) / \sqrt{3} \quad (12)$$

Which gives

$$I_{a1} = (I_a - I_{a0})/2 + ((I_b - I_c) \angle 90^\circ) / 2\sqrt{3} \quad (13)$$

Substituting the value of I_{a0} we get

$$I_{a1} = I_a/2 - ((I_a + I_b + I_c)/6) + ((I_b - I_c) \angle 90^\circ) / \sqrt{3} \quad (13)$$

$$I_{a1} = ((1/3)I_a - (1/6)I_b - (1/6)I_c) + ((I_b - I_c) \angle 90^\circ) / \sqrt{3} \quad (14)$$

Similarly I_{a2} can be found out to be equal to

$$I_{a2} = ((1/3)I_a - (1/6)I_b - (1/6)I_c) - ((I_b - I_c) \angle 90^\circ) / \sqrt{3} \quad (15)$$

Analog implementation

The conventional circuit

A review of conventional methods of sequence component filtering shows that these methods achieve the filtering by directly carrying out the complex transformation between the unbalanced phasors and the desired sequence components. This leads to circuits of considerable complexity. One version of analog sequence filter² is shown in Fig. 2. Note that 'r' and 'C' have a 60 degree phase angle so that, for positive sequence currents, V1 and V2 cancel (i.e. $V1 + V2 = 0$). For zero sequence currents no output is obtained, since they cancel out in the primary windings of the auxiliary CTs.

The proposed circuit

The transactor

Fig. 3 shows the construction of a transactor. The magnetic core is provided with an air gap so as to avoid saturation and therefore maintain linearity of the device. Primary is the current coil and secondary the pressure coil. The burden on the secondary is expected to be small.

Input to the primary of the transactor is current I_p . It produces a sinusoidal flux in phase with this current. Therefore the induced voltage in secondary leads the primary current I_p by 90° . The assumption involved is that the current drawn from the secondary is negligible, thereby there are no secondary ampere-turns to change the phase shift of mutual flux.

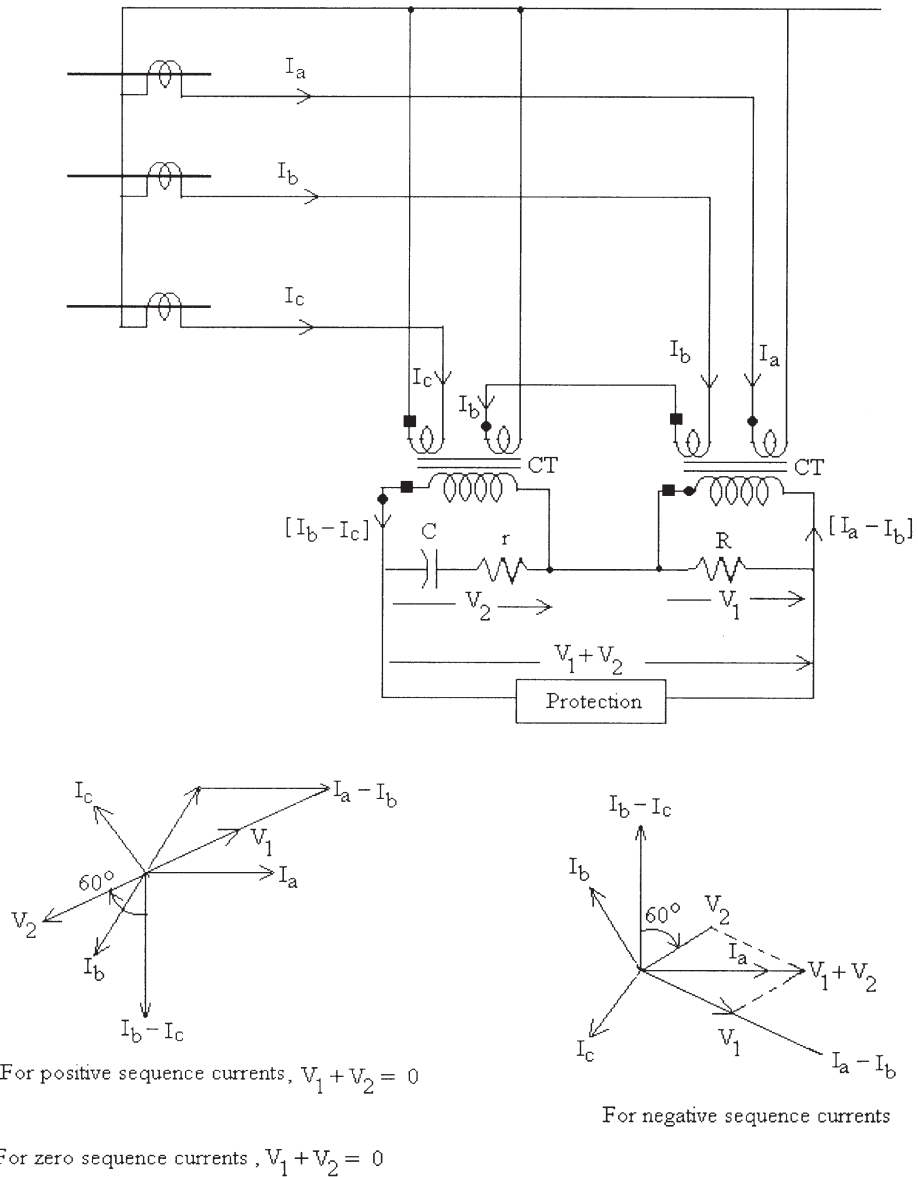

Fig. 2 Conventional Analogue Negative Sequence Filter.

The complete circuit

Simple hardware to implement the equations (14) and (15) is shown in Fig. 4. The three current signals are combined using a transactor. The required phase shift of 90 degrees is obtained as a result of the inherent phase shift between the flux and the induced emf in the transactor.

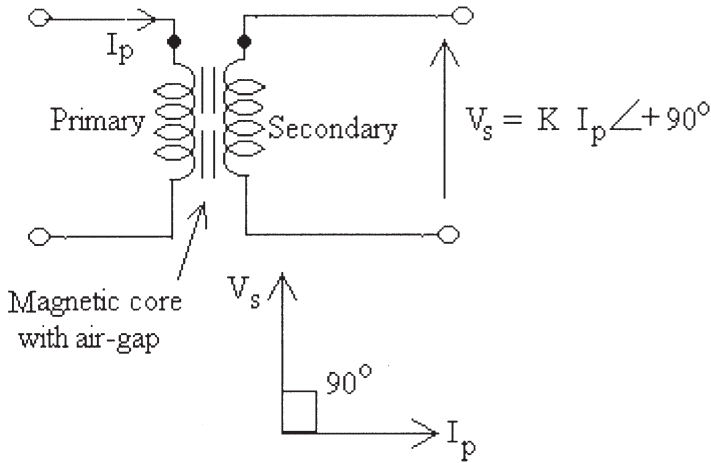

Fig. 3 A Transactor and its phasor diagram.

Digital implementation

The conventional method

The equation of the negative sequence component is

$I_{a2} = (1/3) (I_a + a^2 I_b + a I_c)$; where the operator 'a' is given by

$$a = 1 \angle 120^\circ \text{ and } a^2 = 1 \angle 240^\circ$$

A typical digital implementation is given in Ref.³ where in a sample of $(1/3) I_a$ is added to a sample of $(1/3) I_c$, that is taken 120° apart. This translates to 5.55 milliseconds on a 50Hz basis. Thus the minimum time required to the first estimate of I_{a2} is 240° or 11.1 milliseconds. The number of addition operations required is three.

The proposed method

The negative sequence component is given by the equation

$$I_{a2} = ((1/3)I_a - (1/6)I_b - (1/6)I_c) - ((I_b - I_c) \angle 90^\circ) / \sqrt{3} \quad (15)$$

A sample of $[(1/3)I_a - (1/6)I_b - (1/6)I_c]$ is added to a sample of $[(I_b - I_c) \angle 90^\circ]$ which is taken 90° (5 milliseconds) later. Thus, the minimum time required to get the first estimate of I_{a2} is only 90° or 5 milliseconds. The number of addition operations is two.

Conclusion

It is possible to segregate the sequence components without using the complex filtering schemes involving phase shifts of 120° or 240° as shown in this paper. The proposed method needs a phase shifting operation of 90° , which is easily accom-

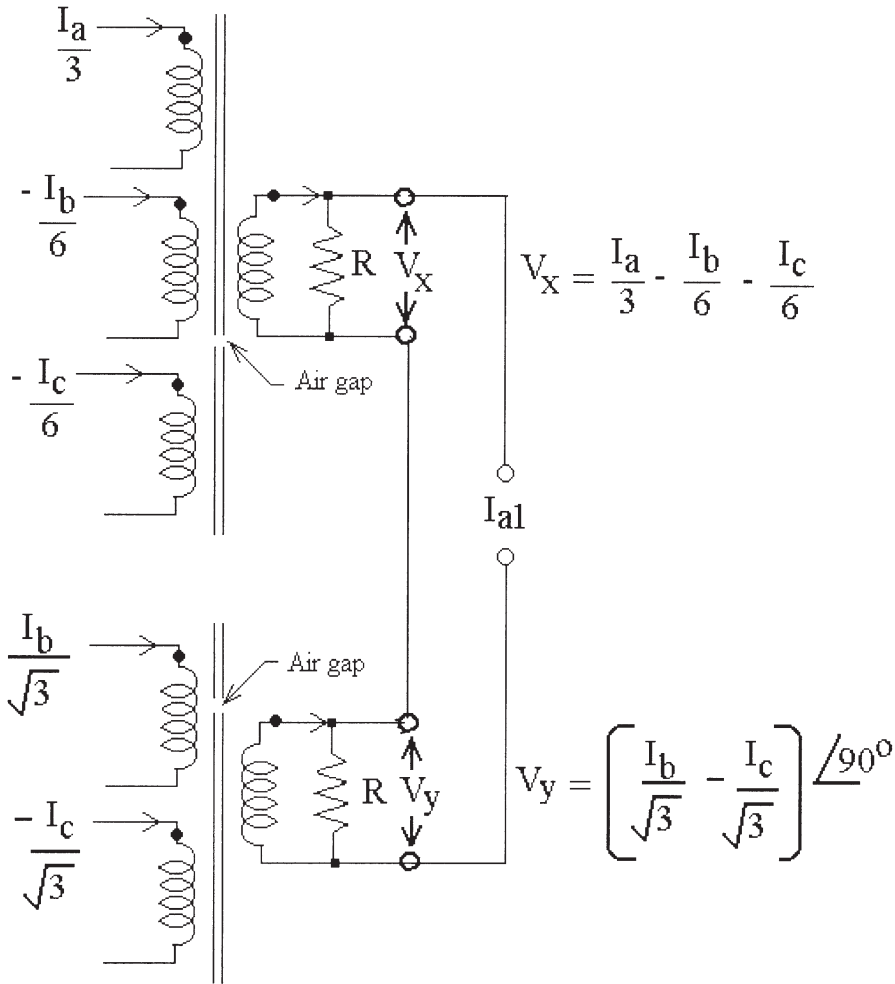

Fig. 4 The proposed negative sequence filter using two transactors.

plished by a transactor. Such a method, it is felt, will simplify the implementation of many protective relays, which depend for their operation on the sequence components. The method also results in a simpler and computationally faster algorithm for extraction of sequence components using the software approach.

References

- 1 W. D. Stevenson, *Elements of Power System Analysis* (Mc Graw-Hill, New York 1955).
- 2 Electricity Training Association, *Power System Protection: Vol. II* (IEE, London 1995).
- 3 Walter A. Elmore (ed), *Protective Relaying Theory and Applications* (Marcel Dekker, New York, 1994).